

# Präzisions - Flachsleifmaschine MPS 2

Schleif-  
maschinen

Genauigkeits  
Maschinenbau  
Nürnberg GmbH



## Charakteristik

Präzisions-Flachsleifmaschine für  
mittlere und grössere Werkstücke

## Einsatzgebiete

- Maschinenbau,
- Feinmechanik,
- Werkzeug- und Vorrichtungsbau,
- Ausbildungswerkstätten.

## Einsatzoptimum

Planschleifen von

- Hartmetallen,
- Schneidkeramik,
- Quarz und Ferrit.

Mit Diamant- und CBN-Schleifscheiben  
lassen sich auch schwierigste Materialien  
wirtschaftlich bearbeiten.



## Zubehör (optional)

- Permanent-Magnetspannplatte
- Nassschleifeinrichtung
- Abrichtvorrichtung
- Auswuchtvorrichtung
- Vakuum-Spannplatten
- mechanische Spannung

## Schleifbereich

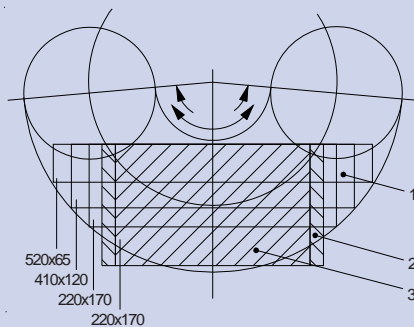

1 effective grinding area

2 table clamping area

3 permanent magnetic chuck area

## Technische Daten

Motor	2,2 kW
Spindeldrehzahl	2560 min <sup>-1</sup>
Elektroanschluss	2,8 kW
Ebenheit Tisch	2 µm
Schleifscheibe	
Keramik	175 x 100 x 76 mm
Diamant / CBN	175 x 40 x 76 mm
Perm. Magnetspannplatte	250 x 150 mm
Schleifhöhe über Magnet	
Keramikschleifscheibe	120 mm
Diamantschleifscheibe	190 mm
Feinzustellung	
Bereich	12 mm
Schleifbereich	(siehe Zeichnung)
Gewicht	286 kg
Platzbedarf	ca. 900 x 900 mm

G&N GmbH, Wetterkreuz 35, 91058 Erlangen, Germany

Telefon: +49 9131 7576-0, Telefax: +49 9131 771291, E-Mail: info@grinders.de, Internet: www.grinders.de

# Precision Surface Grinding Machine MPS 2

Grinding-  
machines

Genauigkeits  
Maschinenbau  
Nürnberg GmbH



## Characteristics

Precision surface grinding machine for medium and large size workpieces.

## Application

- general component manufactures
- precision mechanical assemblies
- tool and die makers
- training facilities

## Application Optimum

Surface grinding of

- carbides
- cutting tool ceramics
- quartz and ferrities

Even the most difficult materials can be machined accurately with diamond or CBN wheels.



## Accessories (optional)

- permanent magnetic chucks
- wet grinding equipment
- dressing attachment
- balancing attachment
- vacuum clamping plate
- mechanic clamping

## Grinding Area

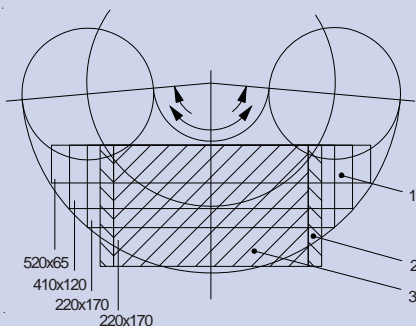

- 1 effective grinding area
- 2 table clamping area
- 3 permanent magnetic chuck area

## Technical Data

A.C. Motor	2.2 kW
Spindle speed	2560 rpm
Power connection	2.8 kW
Flatness table	2 µm
Grinding wheel	
vitriified	175 x 100 x 76 mm
Diamond/CBN	175 x 40 x 76 mm
permanent mag. chuck	250 x 150 mm
Grinding height	
Vitriified wheel	120 mm
Diamond wheel	190 mm
Fine downfeed	
Range	12 mm
grinding area	(see sketch)
Weight	286 kg
Area	app. 900 x 900 mm

G&N GmbH, Wetterkreuz 35, 91058 Erlangen, Germany

Telefon: +49 9131 7576-0, Telefax: +49 9131 771291, E-Mail: info@grinders.de, Internet: www.grinders.de